

**MEULES DIAMANTEES / MEULES AU NITRURE DE BORE (CBN)**  
**DIAMANTSCHLEIFSCHLEIBEN / BORNITRIDSCHLEIFSCHLEIBEN (CBN)**  
**DIAMOND GRINDING WHEELS / BORON NITRIDE GRINDING WHEELS (CBN)**

Forme Form Form	Croquis Skizze Style	Usage Anwendung Application
12A2 45°		<p>Pour l'affûtage d'outils de coupe multiple avec plaquettes en métal dur.</p> <p>Zum Schleifen von hartmetallbestückten Schneid-Werkzeugen.</p> <p>For the grinding of cutting tools with brazed tips.</p>

D × W × X [mm]	Grain Körnung Gritt	Conc. Konz. Conc.	Liant Bindung Bond	H	T	E
75 × 3 × 4	D10 D15	C75	E505KH	20	25	10
75 × 3 × 4	D20 D25	C75	E505E	20	25	10
75 × 3 × 4	D46 D54 D64 D76 D91 D126	C75	E545P	20	25	10
100 × 3 × 4	D20	C75	E505E	20	25	10
100 × 3 × 4	D46 D107	C75	E545P	20	25	10

Forme Form Form	Croquis Skizze Style	Usage Anwendung Application
11V9		<p>Pour l'affûtage d'outils avec plaquettes en métal dur permettant aussi le détaillage du corps acier.</p> <p>Zum Schleifen von hartmetallbestückten Schneid-Werkzeugen, auch mit bis 50% Anteil an Schaft-Material.</p> <p>For the grinding of cutting tools with brazed tips allowing for grinding of the steels shanks.</p>

D × W × X [mm]	Grain Körnung Gritt	Conc. Konz. Conc.	Liant Bindung Bond	H	T	E
75 × 2 × 10	D15 D64 D126	C75	E503S	20	30	10
100 × 2 × 10	D64 D126	C75	E503S	20	35	10
100 × 3 × 10	D107 D126	C75	E503S	20	35	10
125 × 2 × 10	D20	C75	E503S	20	40	10
125 × 3 × 10	D64 D91 D126 D151	C75	E503S	20	40	10
150 × 2 × 10	D64 D91 D126	C75	E503S	20	50	10
150 × 3 × 10	D64 D91 D126	C75	E503S	20	50	10

**Disponible en Borazon    Verfügbar in Borazon    Available funds to Borazon**

**MEULES DIAMANTEES / MEULES AU NITRURE DE BORE (CBN)**  
**DIAMANTSCHLEIFSCHLEIBEN / BORNITRIDSCHLEIFSCHLEIBEN (CBN)**  
**DIAMOND GRINDING WHEELS / BORON NITRIDE GRINDING WHEELS (CBN)**

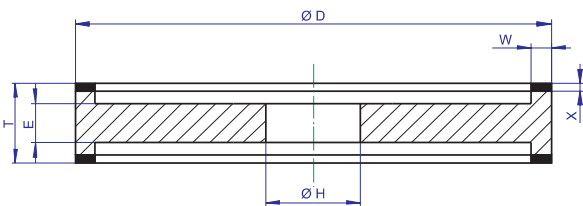
Forme Form Form	Croquis Skizze Style	Usage Anwendung Application
9A3		<p>Pour l'affûtage de burins de tournage et de décolletage avec plaquettes en métal dur.            Zum Schleifen von präzisen hartmetallbestückten Drehmeisseln und Automatenstählen.            For the grinding of turning and part-off tools for automatics (carbide tipped).</p>

D × W × X [mm]	Grain Körnung Gritt	Conc. Konz. Conc.	Liant Bindung Bond	H	T	E
125 × 6 × 2	D20 D30	C75	E505E	12	22	10
125 × 6 × 2	D91 D126	C75	E505P	12	22	10
150 × 6 × 2	D20 D30	C75	E545E	16	25/35	14
150 × 6 × 2	D91 D126	C75	E505P	16	25/35	14
175 × 4 × 2	D20 D30	C75	E545E	20	25/35	14
175 × 4 × 2	D91 D126	C75	E503P	20	25/35	14
175 × 6 × 2	D15 D20 D30	C75	E503E	20	25/35	14
175 × 6 × 2	D91 D126	C75	E503P	20	25/35	14

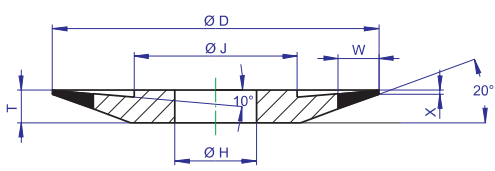
Forme Form Form	Croquis Skizze Style	Usage Anwendung Application
4BT9		<p>Taillage du métal dur.            Trennen / Formschleifen.            For the grinding of solid carbide tools.</p>

D × W × X [mm]	Grain Körnung Gritt	Conc. Konz. Conc.	Liant Bindung Bond	H	T	J
75 × 6 × 0.3	D15 D91	C75	E510Q	20	8	40
75 × 6 × 0.3	D20	C75	E505E	20	8	40
75 × 6 × 0.3	D30 D46 D54	C75	E503P	20	8	40
75 × 6 × 0.5	D15	C75	E505E	20	8	40
75 × 6 × 0.5	D20	C75	E510Q	20	8	40
75 × 6 × 0.5	D46	C75	E503P	20	8	40
75 × 6 × 0.5	D91 D126	C75	E503S	20	8	40

**Disponible en Borazon    Verfügbar in Borazon    Available funds to Borazon**

**MEULES DIAMANTEES / MEULES AU NITRURE DE BORE (CBN)**  
**DIAMANTSCHLEIFSCHLEIBEN / BORNITRIDSCHLEIFSCHLEIBEN (CBN)**  
**DIAMOND GRINDING WHEELS / BORON NITRIDE GRINDING WHEELS (CBN)**

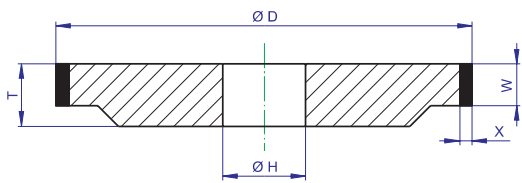
Forme Form Form	Croquis Skizze Style	Usage Anwendung Application
1A1		Pour rectification plane et cylindrique d'outils en métal dur. Zum Flach- und Rundschleifen von hartmetallbestückten Werkzeugen. For grinding flat and cylindrical carbide tools.

D × W × X [mm]	Grain Körnung Gritt	Conc. Konz. Conc.	Liant Bindung Bond	H	T
75 × 4 × 3	D20 D46 D107	C75	E505E E545P E545P	20	8
100 × 4 × 3	D25 D46 D107	C75	E505E E545P E503P	20	8
125 × 3 × 6	D46	C75	E503P	20	10
125 × 5 × 6	D46	C75	E545P	20	10
125 × 6 × 6	D46	C75	E545P	20	10
150 × 5 × 6	D46	C75	E545P	20	10
150 × 6 × 6	D46	C75	E545P	20	10
150 × 8 × 6	D46	C75	E545P	20	10
200 × 8 × 3	D126	C75	E545P	50	10
250 × 10 × 3	D126	C75	E545P	70	12
300 × 10 × 3	D20 D46 D126	C75	E545P E545P E545P	127	20
300 × 20 × 3	D91 D126	C75	E545P E545P E545P	127	20

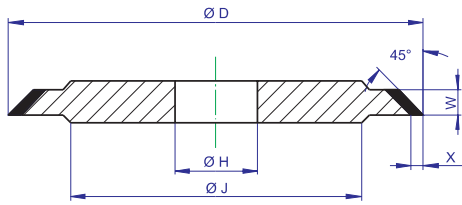
Forme Form Form	Croquis Skizze Style	Usage Anwendung Application
1V1 45°		Rectification du métal dur en passe profonde sur machine CNC. Zum Schleifen von Hartmetallen für tiefe Operationen auf CNC-Maschinen. For grinding of solide carbide with deep cuts on CNC machines.

D × W × X [mm]	Grain Körnung Gritt	Conc. Konz. Conc.	Liant Bindung Bond	H	T	J
75 × 4 × 3	D46 D64 D91 D126	C75	E503S	20	10	50
75 × 6 × 5	D46 D64 D91 D126	C75	E503S	20	10	50
100 × 6 × 8	D46 D64 D91 D126	C75	E503S	20	10	70

**Disponible en Borazon    Verfügbar in Borazon    Available funds to Borazon**

**MEULES DIAMANTEES / MEULES AU NITRURE DE BORE (CBN)**  
**DIAMANTSCHLEIFSCHLEIBEN / BORNITRIDSCHLEIFSCHLEIBEN (CBN)**  
**DIAMOND GRINDING WHEELS / BORON NITRIDE GRINDING WHEELS (CBN)**

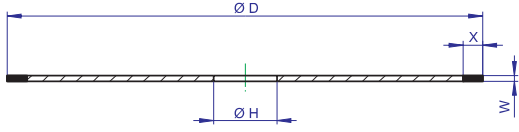
Forme Form Form	Croquis Skizze Style	Usage Anwendung Application
1A1R		Tronçonnage de barreaux en métal dur, HSS ou acier trempé. Trennen von Hartmetallstäben, HSS oder gehärtetem Stahl. Slitting discs for solid carbide, speed steel or steel..

D × W × X [mm]	Grain Körnung Gritt	Conc. Konz. Conc.	Liant Bindung Bond	H
40 × 1 × 20	D76	C150	E510P	6 / 10
50 × 1 × 20	D76	C150	E510P	10
75 × 0.6 × 5	D126	C150	E510P	10 / 20
75 × 0.7 × 5	D126	C150	E510P	10 / 20
75 × 0.8 × 5	D126	C150	E510P	10 / 20
75 × 1 × 5	D126	C150	E510P	10 / 20
80 × 0.8 × 5	D126	C150	E510P	10 / 20
80 × 1 × 5	D126	C150	E510P	10 / 20
100 × 1 × 5	D126	C150	E510P	10 / 20

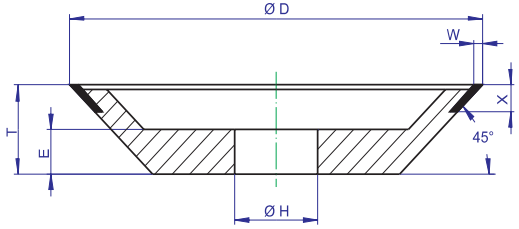
Forme Form Form	Croquis Skizze Style	Usage Anwendung Application
12V9		Pour l'affûtage d'outils avec plaquettes en métal dur permettant aussi le détallonnage du corps acier. Zum Schleifen von hartmetallbestückten Schneid-Werkzeugen, auch mit bis 50% Anteil an Schaft-Material. For the grinding of cutting tools with brazed tips allowing for grinding of the steels shanks.

D × W × X [mm]	Grain Körnung Gritt	Conc. Konz. Conc.	Liant Bindung Bond	H	T	J
75 × 2 × 6	D20	C50	E505E	20	20	10
75 × 2 × 6	D107	C75	E503S	20	20	10
100 × 2 × 6	D20	C50	E505E	20	20	10
100 × 2 × 6	D107	C75	E503S	20	20	10

**Disponibile en Borazon    Verfügbar in Borazon    Available funds to Borazon**